

Dealing With Plagiarism

This document is provided FREE from the author's
blog at <http://www.scrawlbug.com>
The original version was published at <http://www.wordophilia.com>
on April 8, 2009.

If someone made you pay for this, tell the world they're a scammer.

© Copyright 2009 Spike Wyatt



This document is published under a Creative Commons
Attribution Share Alike license.

It can be remixed, added to and tweaked as much as you like, even for
commercial purposes, provided you attribute it to the original author
and apply the same license to any future versions.

plagiarism *–noun* The unauthorized use or close imitation of the language and thoughts of another author and the representation of them as one's own original work.
(Dictionary.com Unabridged. Based on the Random House Dictionary, © Random House, Inc. 2009.)

Anyone who's written an article, editorial, opinion piece, newsletter or even just published a web page runs the risk of suffering from plagiarism. Stealing other people's work used to be a more involved proposal: the piece had to be copied or rephrased by hand from an original. However, with the advent of electronic documents and the Web, it's become a simple matter of copying and pasting text. There's even [an entire web site](#) of resources for teachers and lecturers, to help in educating students and detecting the activity (which, according to Wilson Pon at the [Techno Stuffs](#) blog is a great tool: he uses it to check his students' coursework!).

Watching For Copies

Despite the huge number of web pages in the world, watching for plagiarism is, in some ways, easier than before thanks to search engines. By regularly checking for the presence of pertinent phrases, an author can keep an eye on who's using their work and ensure they are paid - or at least credited. However, more prolific writers soon find this tracking ponderous and time-consuming. How to make it easier?

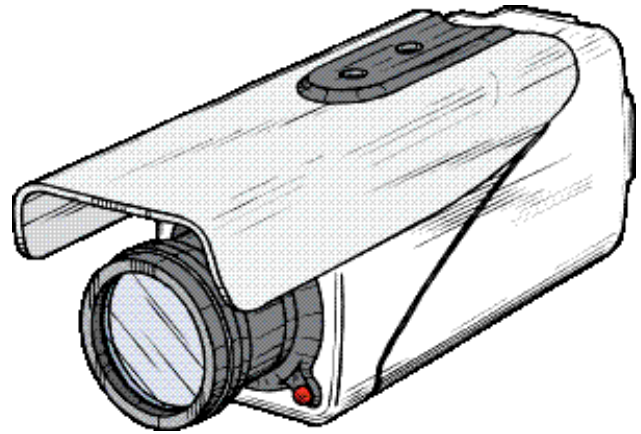

An excellent tip I picked up a few months ago is to use [Google Alerts](#). This is a free service that performs a custom search on a phrase of up to 32 words. Google subscribers - that is, anyone who has an account with them for any of their other services such as Gmail or AdSense - can also store their alerts, so that regular checks are run automatically.

Each alert is simple to set up. Log in and create a new alert, then copy thirty or so words from the article or other piece of writing into the text box provided. Don't forget to start and end with a double-quote character, so that the Alert looks for the whole phrase, rather than the individual words. You can then decide if you want daily, weekly or as-seen updates on changes: an email will be scheduled automatically by the service whenever it detects a new page with the text present. These go to your Google-registered email account and allow you to verify that the content is not stolen.

An alternative is the [Copyscape](#) site, which is used by an enormous number of professionals to verify that independently-submitted content (usually from freelancers) is not stolen from elsewhere on the Internet. The site also provides a paid service called Copy Sentry, which monitors for copies of subscribers' work and emails the author as soon as a duplicate appears.

Copies Of Images

For artists and photographers, the Alerts service and Copyscape won't work: they only detect text. However, there are some alternatives. For smaller producers, there's a free manual checking utility over at [TinEye](#) which will search through a couple of billion online images to see if your work has been posted anywhere. You can either upload an image to check or provide a URL. The TinEye service will also check for resized versions and those that have been cropped, to an extent.

If you're producing a huge amount of images professionally, a more complete service is available through [Digimarc](#). This is a subscription service which, for a monthly fee, provides digital watermarking for images, online storage, contact information for people wishing to use your work (and pay for it) and a tracking system to see where your pictures are being used.

Dealing With Plagiarism

Should you detect plagiarism, the best option is always to contact the thief. You can check who owns any particular domain by using a 'whois' service, such as [the one at DomainTools](#), where registration details are stored. These always include a contact email. I tend to send a plain email, stating simply that there is stolen content on their site, the URL of the content and three options: take it down, pay me (or credit me) or face the consequences. The majority of site owners will ensure the content is removed.



If they refuse to remove the content or do not reply, the next move depends on where they operate. Contacting their ISP will sometimes have an effect, since most ISP terms of service contain a clause regarding legal content and respecting copyright. If the site runs Google's AdSense, you can threaten to [report it to the search engine people](#) and get the account banned - that'll make them sit up and take notice! If they're in the same country as you, you could even go as far as taking legal action: internationally, this is obviously much more difficult.

However you deal with it, it's also worth notifying people who use the same publication service, where your original was displayed. They may want to check that their content is safe, too.